

RG-CF Series Next- Generation High- Performance Firewalls

Hardware Installation and Reference Guide

Copyright

Copyright © 2026 Ruijie Networks

All rights are reserved in this document and this statement.

Without the prior written consent of Ruijie Networks, no organization or individual is permitted to reproduce, extract, back up, modify, or distribute the content of this document in any manner or form. It is also prohibited to translate the document into other languages or use any or all parts of it for commercial purposes.



and other Ruijie networks logos are trademarks of Ruijie Networks.

All other trademarks or registered trademarks mentioned in this document are owned by their respective owners.

Disclaimer

The products, services, or features that you purchase are subject to commercial contracts and terms. It is possible that some or all of the products, services, or features described in this document may not be available for purchase or use. Unless agreed upon otherwise in the contract, Ruijie Networks does not provide any explicit or implicit statements or warranties regarding the content of this document.

The names, links, descriptions, screenshots, and any other information regarding third-party software mentioned in this document are provided for your reference only. Ruijie Networks does not explicitly or implicitly endorse or recommend the use of any third-party software and does not make any assurances or guarantees concerning the applicability, security, or legality of such software. You should choose and use third-party software based on your business requirements and obtain proper authorization. Ruijie Networks assumes no liability for any risks or damages arising from your use of third-party software.

The content of this document is subject to constant change due to product version upgrades or other reasons. Thus, Ruijie Networks reserves the right to modify the content of the document without prior notice or prompt.

This manual serves solely as a user guide. While Ruijie Networks endeavors to ensure the accuracy and reliability of the content when compiling this manual, it does not guarantee that the content of the manual is free of errors or omissions. All information contained in this manual does not constitute any explicit or implicit warranties.

Personal Data Statement

During the operation or troubleshooting of the products, services, or features you have purchased, certain personal data of users may be collected or used. Therefore, it is essential for you to establish and implement appropriate privacy policies, in compliance with the relevant laws and regulations of the applicable countries or regions, to ensure the complete protection of users' personal data.

If Ruijie Networks is involved in this process, we will strictly adhere to the relevant laws and regulations of the applicable countries or regions and take all necessary actions to safeguard users' personal data.

When discarding, reclaiming, or reusing a device, please ensure to back up or clear any stored data to avoid data leakage. For assistance, please contact our after-sales technical support.

Preface

Intended Audience

This document is intended for:

- Network engineers
- Technical support and servicing engineers
- Network administrators

Technical Support

- Ruijie Networks website: <https://www.ruijie.com>
- Online support center: <https://www.ruijie.com/support>
- Case portal: <https://caseportal.ruijie.com>
- Community: <https://community.ruijie.com>
- Email support: service_rj@ruijie.com
- Live chat: <https://www.ruijie.com/rita>
- Documentation feedback: doc@ruijie.com.cn

Conventions

1. Signs

The signs used in this document are described as follows:

 **Danger**
An alert that calls attention to safety instruction that if not understood or followed can result in personal injury.

 **Warning**
An alert that calls attention to important rules and information that if not understood or followed can result in data loss or equipment damage.

 **Caution**
An alert that calls attention to essential information that if not understood or followed can result in function failure or performance degradation.

 **Note**
An alert that contains additional or supplementary information that if not understood or followed will not lead to serious consequences.

 **Specification**
An alert that contains a description of product or version support.

2. Notes

This manual provides installation steps, troubleshooting, technical specifications, and usage guidelines for cables and connectors. It is intended for users who want to understand the above and have extensive experience in network deployment and management, and assume that users are familiar with related terms and concepts.

Contents

Preface	I
1 Overview	4
1.1 About the RG-CF Series	4
1.2 RG-CF10S	4
1.2.1 Equipment Appearance	4
1.2.2 Technical Specifications	6
1.2.3 Cooling	7
1.3 RG-CF10S-LTE	7
1.3.1 Equipment Appearance	7
1.3.2 Technical Specifications	11
1.3.3 Cooling	12
1.4 RG-CF30XS	13
1.4.1 Equipment Appearance	13
1.4.2 Technical Specifications	15
1.4.3 Cooling	17
1.5 Modules	17
1.5.1 Hard Disk Modules	17
1.5.2 4G Module	19
2 Preparing for Installation	22
2.1 Safety Guidelines	22
2.1.1 General Precautions	22
2.1.2 Chassis-Lifting Guidelines	23

2.1.3 Electricity Safety	23
2.1.4 Preventing ESD Damage.....	23
2.1.5 Laser Safety	23
2.2 Site Requirements	23
2.2.1 Airflow.....	24
2.2.2 Space	24
2.2.3 Temperature and Humidity.....	24
2.2.4 Cleanliness.....	24
2.2.5 Grounding	25
2.2.6 Preventing Electromagnetic Interference	26
2.2.7 Surge Protection	26
2.2.8 Installation Site.....	26
2.3 Tools	26
2.4 Unboxing and Inspection	27
3 Installing the Firewall.....	28
3.1 Installation Procedure	28
3.2 Before You Begin.....	28
3.3 (Optional) Installing the Hard Disk Module.....	29
3.4 (Optional) Installing the 4G Module.....	30
3.5 Installing the Equipment in a Specified Position.....	31
3.5.1 Installing the Equipment in a Rack	31
3.5.2 Installing the Equipment on a Workbench	34
3.6 Connecting the Grounding Wire	34
3.7 Connecting the Power Cord.....	35

3.8 Verifying Installation.....	38
4 Commissioning.....	39
4.1 Setting Up the Configuration Environment.....	39
4.2 Power-on.....	39
4.2.1 Checklist Before Power-on	39
4.2.2 Power-on.....	39
4.2.3 Checklist After Power-on	39
4.3 Configuring the Equipment	40
5 Troubleshooting.....	41
5.1 Optical Port Is Down	41
5.1.1 Issue Description	41
5.1.2 Solution	41
Appendix A. 1GE SFP Transceivers.....	42
Appendix B. 10GE SFP+ Transceivers	43

1 Overview

1.1 About the RG-CF Series

The RG-CF series firewalls use a DPDK-based high-performance network forwarding service platform to provide intelligent quick deployment, active asset discovery, intelligent policy manager, one-click fault analysis, and service health diagnosis, simplifying device deployment and O&M. They have rich security functions, including intrusion prevention, antivirus, port scan, traffic learning, application control, and defense against DoS/DDoS attacks. They also support unified management on the cloud platform, data synchronization to the cloud for analysis and reporting, remote monitoring and O&M, policy translation for device replacement, batch configuration, and automatic inspection.

1.2 RG-CF10S

1.2.1 Equipment Appearance

The RG-CF10S provides eight 10/100/1000BASE-T ports, two 1GE SFP ports, one management port, one USB 3.0 port, and one console port.

The nameplate is located on the bottom of the firewall. It provides information, such as the IP address of the management interface, and default login username and password.

1. Front Panel

Figure 1-1 Front Panel

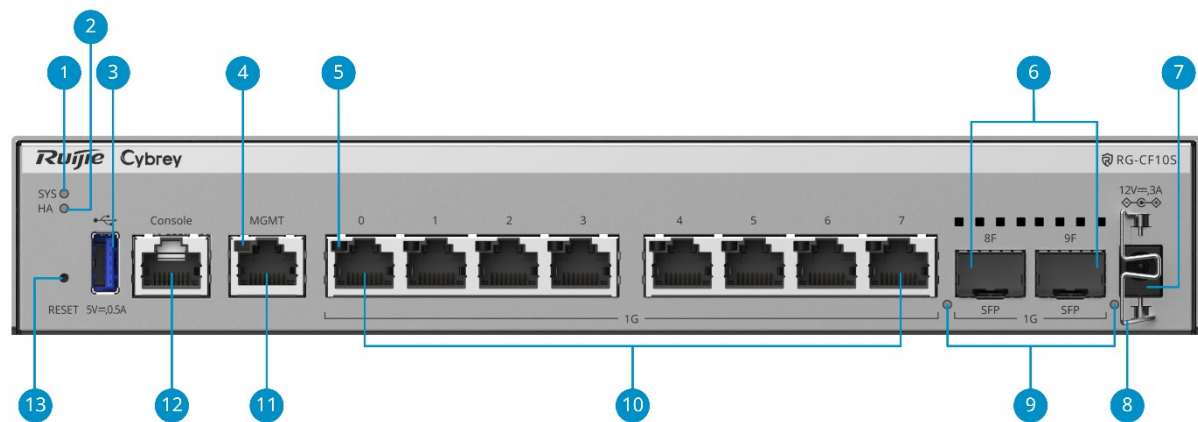

Table 1-1 Components on the Front Panel

No.	Component	Description
1	System status LED (SYS)	<ul style="list-style-type: none"> ● Solid green: The system is operating normally. ● Blinking green: The system is being initialized. If the LED is in this state for a long time, the system malfunctions. ● Solid red: A system fault occurs or the device temperature exceeds the normal operating temperature range. ● Off: The system is not powered on.

No.	Component	Description
2	HA active/standby LED (HA)	<ul style="list-style-type: none"> ● Solid green: The high availability (HA) system works normally and the device is operating in the active role. ● Blinking green: The HA system works normally and the device is operating in the standby role. ● Solid red: The HA system malfunctions. ● Off: The HA system is disabled.
3	USB port	One USB 3.0 port for connecting a USB flash drive. Note: External storage devices cannot be used for log storage.
4	Management port LED	<ul style="list-style-type: none"> ● Solid green: A link is set up on the port. ● Blinking green: The port is receiving or sending data. ● Off: The link on the port is Down.
5	10/100/1000BASE-T port LED	<ul style="list-style-type: none"> ● Solid green: A link is set up on the port. ● Blinking green: The port is receiving or sending data. ● Off: The link on the port is Down.
6	1GE SFP ports	Two 1GE optical ports (8F and 9F).
7	12 V power connector	Used to connect the power cord and supply power to the device.
8	Power cord retention clip	Used to secure the power cord.
9	1GE SFP port status LED	<ul style="list-style-type: none"> ● Solid green: A link is set up on the port. ● Blinking green: The port is receiving or sending data. ● Off: The link on the port is Down.
10	10/100/1000BASE-T ports	Eight 10/100/1000BASE-T ports (0–7), supporting auto-negotiation at 10 Mbps, 100 Mbps, or 1000 Mbps and connecting Ethernet cables with RJ45 connectors.
11	Management port	The management port has a default IP address (10.20.30.42/24). Upon first login, you can log in to the web management page of the device through the management port.
12	Console port	Connects to the device console for device maintenance and troubleshooting. Note: <ul style="list-style-type: none"> ● When the console port is used, set the baud rate to 115200 bps, data bit to 8, stop bit to 1, with no parity check and data flow control. ● The console port is only used in special scenarios. For detailed operations, contact technical support.
13	Reset button	<ul style="list-style-type: none"> ● Device restart: Press and hold the button for less than 5s. ● Factory reset: Press and hold the button for more than 5s. Both operations will trigger automatic collection of equipment information. After startup, choose O&M > Fault Diagnosis > One-Click Collection , and download the equipment status information.

2. Rear Panel

Figure 1-2 Rear Panel

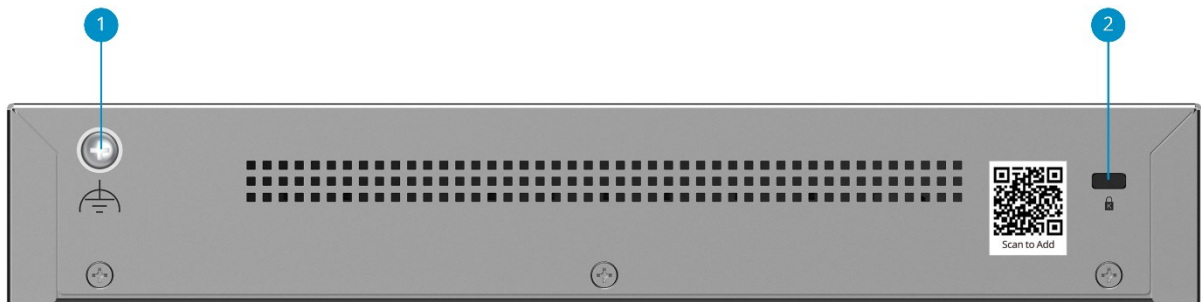

Table 1-2 Components on the Rear Panel

No.	Component	Description
1	Grounding screw	Connects the grounding wire to ensure electrical safety.
2	Kensington lock slot	Used to install a Kensington lock to prevent equipment loss. The equipment is not delivered with a Kensington lock by default. You need to purchase it separately.

1.2.2 Technical Specifications

Table 1-3 Technical Specifications

Model	RG-CF10S
Memory	2 GB DDR4 (ECC not supported)
Flash memory	64 GB eMMC
Hard disk	Not supported
Fixed service port	<ul style="list-style-type: none"> ● 8 x 10/100/1000BASE-T ports ● 2 x 1GE SFP ports: For details about the supported optical transceiver models, see Section Appendix A 1GE SFP Transceivers.
Fixed management port	<ul style="list-style-type: none"> ● 1 x RJ45 management port ● 1 x RJ45 console port
USB port	1 x USB 3.0 port
Bypass port	Not supported
Expansion module	Not supported
Unit dimensions (W x D x H)	260 mm x 170.3 mm x 43.3 mm (10.24 in. x 6.70 in. x 1.70 in.; without rubber pads)
Unit weight	1.6 kg (3.53 lbs)
Power supply	1 x external power adapter

Rated input voltage	12 V
Maximum input voltage	12.5 V
Rated input current	2 A
Maximum input current	3 A
Maximum power consumption	15 W
Operating temperature	0°C to 45°C (32°F to 113°F) at a height below 1,800 m (5,905.51 ft.) above the sea level Note: At an altitude between 1,800 m (5,905.51 ft.) and 5,000 m (16,404.20 ft.), every time the altitude increases by 220 m (721.78 ft.), the maximum temperature decreases by 1°C (1.8°F).
Operating humidity	10% RH to 90% RH (non-condensing)
Storage temperature	–40°C to 70°C (–40°F to 158°F)
Storage humidity	5% RH to 95% RH (non-condensing)
Operating altitude	0 m to 5,000 m (0 ft. to 16,404 ft.)

⚠ Caution

Due to the wide variety of USB flash drives, the firewall may not support some of them. You are advised to use a genuine Kingston USB flash drive formatted with the FAT32 file system.

1.2.3 Cooling

The RG-CF10S adopts natural cooling. To ensure that the equipment works properly in the specified environment, maintain sufficient clearance around the equipment for air circulation and ventilation.

1.3 RG-CF10S-LTE

1.3.1 Equipment Appearance

The RG-CF10S-LTE provides eight 10/100/1000BASE-T ports, two 1GE SFP ports, one management port, one USB 3.0 port, and one console port on the front panel. The rear panel includes two 4G antenna ports and one Kensington lock slot

The nameplate is located on the bottom of the firewall. It provides information, such as the IP address of the management interface, and default login username and password.

1. Front Panel

Figure 1-3 Front Panel

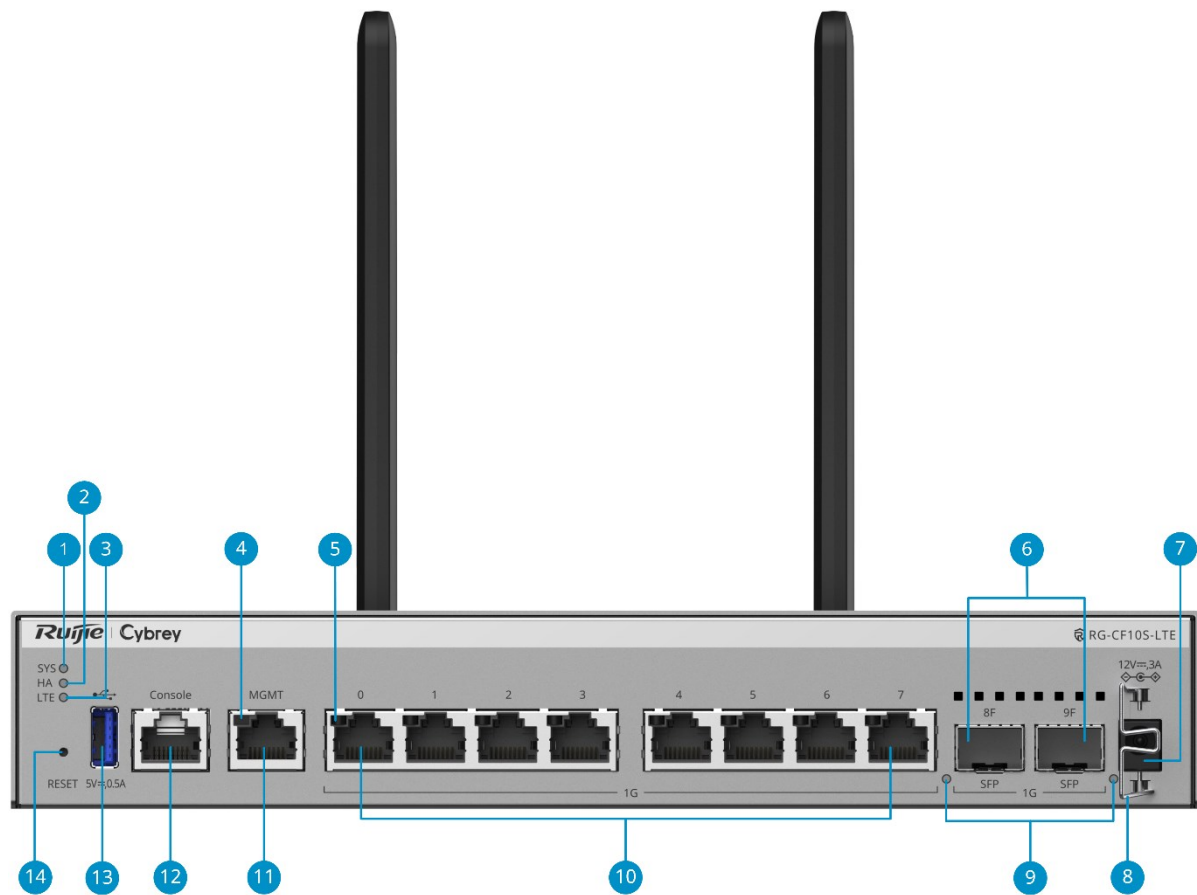

Table 1-4 Components on the Front Panel

No.	Component	Description
1	System status LED (SYS)	<ul style="list-style-type: none"> ● Solid green: The system is operating normally. ● Blinking green: The system is being initialized. If the LED is in this state for a long time, the system malfunctions. ● Solid red: A system fault occurs or the device temperature exceeds the normal operating temperature range. ● Off: The system is not powered on.
2	HA active/standby LED (HA)	<ul style="list-style-type: none"> ● Solid green: The HA system works normally and the device is operating in the active role. ● Blinking green: The HA system works normally and the device is operating in the standby role. ● Solid red: The HA system malfunctions. ● Off: The HA system is disabled.
3	4G status LTE LED (LTE)	<ul style="list-style-type: none"> ● Solid green: The cellular service is available. ● Blinking green: The equipment is dialing. ● Solid red: The cellular service is faulty. ● Off: The cellular service is disabled.

No.	Component	Description
4	Management port LED	<ul style="list-style-type: none"> ● Solid green: A link is set up on the port. ● Blinking green: The port is receiving or sending data. ● Off: The link on the port is Down.
5	10/100/1000BASE-T port LED	<ul style="list-style-type: none"> ● Solid green: A link is set up on the port. ● Blinking green: The port is receiving or sending data. ● Off: The link on the port is Down.
6	1GE SFP ports	Two 1GE optical ports (8F and 9F).
7	12 V power connector	Used to connect the power cord and supply power to the device.
8	Power cord retention clip	Used to secure the power cord.
9	1GE SFP port status LED	<ul style="list-style-type: none"> ● Solid green: A link is set up on the port. ● Blinking green: The port is receiving or sending data. ● Off: The link on the port is Down.
10	10/100/1000BASE-T ports	Eight 10/100/1000BASE-T ports (0–7), supporting auto-negotiation at 10 Mbps, 100 Mbps, or 1000 Mbps and connecting Ethernet cables with RJ45 connectors.
11	Management port	The management port has a default IP address (10.20.30.42/24). Upon first login, you can log in to the web management page of the device through the management port.
12	Console port	<p>Connects to the device console for device maintenance and troubleshooting.</p> <p>Note:</p> <ul style="list-style-type: none"> ● When the console port is used, set the baud rate to 115200 bps, data bit to 8, stop bit to 1, with no parity check and data flow control. ● The console port is only used in special scenarios. For detailed operations, contact technical support.
13	USB port	<p>One USB 3.0 port for connecting a USB flash drive.</p> <p>Note: External storage devices cannot be used for log storage.</p>
14	Reset button	<ul style="list-style-type: none"> ● Device restart: Press and hold the button for less than 5s. ● Factory reset: Press and hold the button for more than 5s. <p>Both operations will trigger automatic collection of equipment information. After startup, choose O&M > Fault Diagnosis > One-Click Collection, and download the equipment status information.</p>

2. Rear Panel

Figure 1-4 Rear Panel

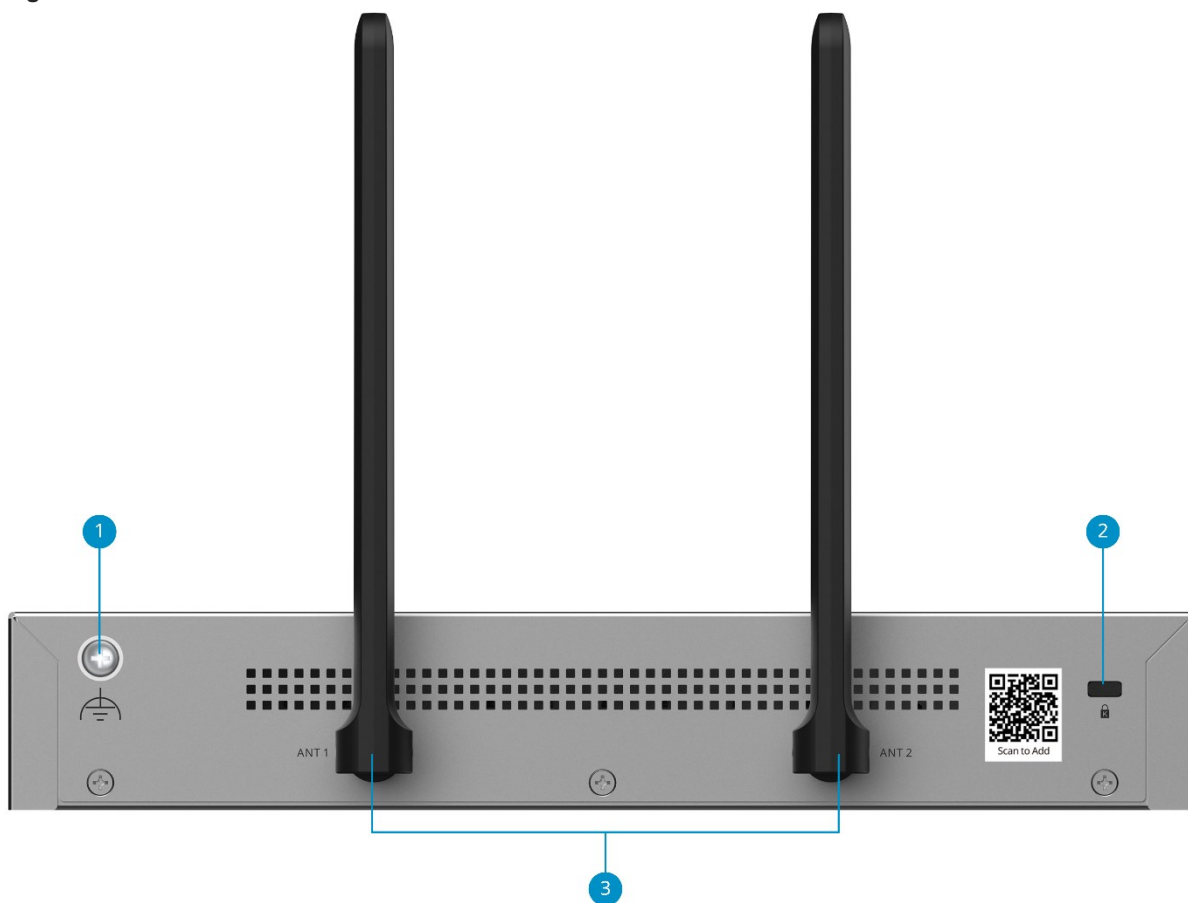
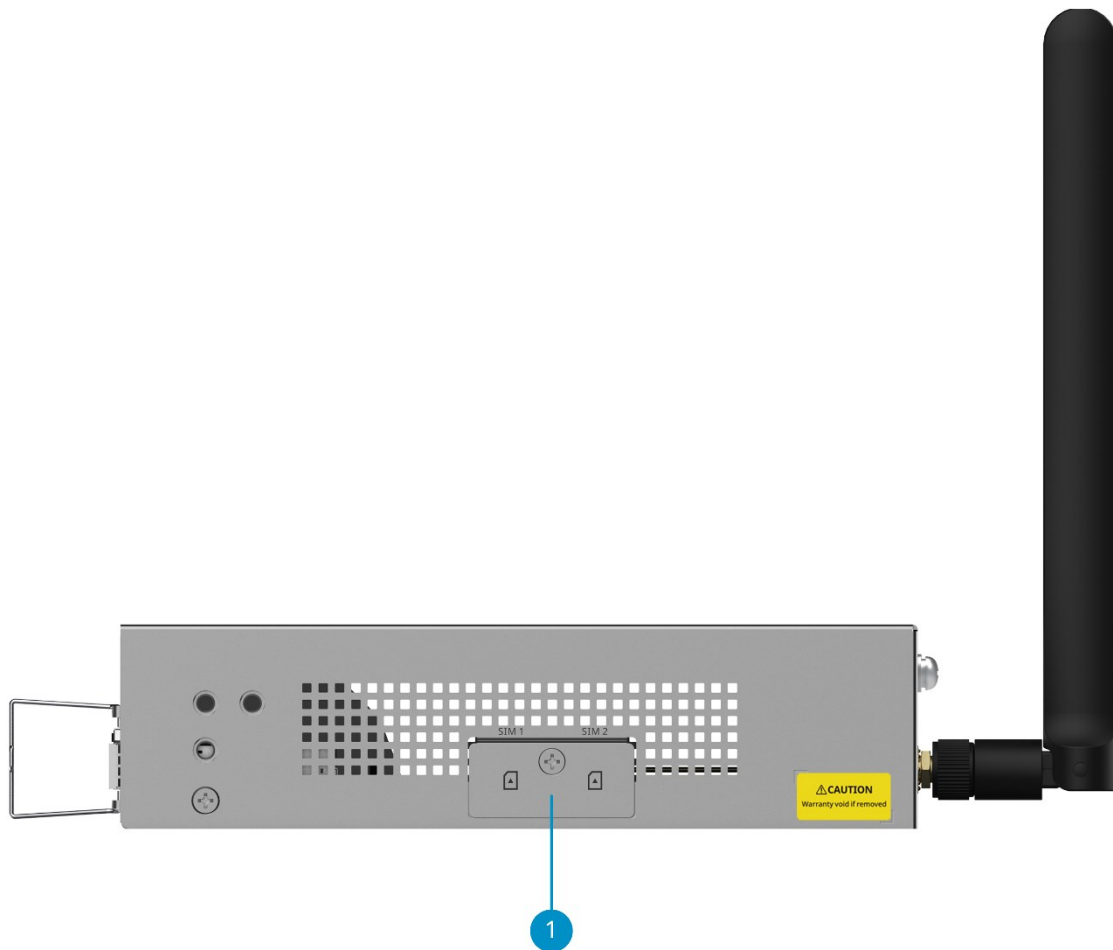

Table 1-5 Components on the Rear Panel

No.	Component	Description
1	Grounding screw	Connects the grounding wire to ensure electrical safety.
2	Kensington lock slot	Used to install a Kensington lock to prevent equipment loss. The equipment is not delivered with a Kensington lock by default. You need to purchase it separately.
3	4G antenna	Used to receive and transmit the 3G or 4G signal and optimize the network quality.

2. Right Panel



No.	Component	Description
1	SIM card slot 1 (left) and SIM card slot 2 (right)	Used to accommodate SIM cards.

1.3.2 Technical Specifications

Table 1-6 Technical Specifications

Model	RG-CF10S-LTE
Memory	2 GB DDR4 (ECC not supported)
Flash memory	64 GB eMMC
Hard disk	Not supported
Fixed service port	<ul style="list-style-type: none"> ● 8 x 10/100/1000BASE-T ports ● 2 x 1GE SFP ports: For details about the supported optical transceiver models, see Section Appendix A 1GE SFP Transceivers.
Fixed management port	<ul style="list-style-type: none"> ● 1 x RJ45 management port ● 1 x RJ45 console port

USB port	1 x USB 3.0 port
4G port	1 x built-in 4G module
SIM card	Dual SIM Single Standby
Bypass port	Not supported
Expansion module	Not supported
Unit dimensions (W x D x H)	260 mm x 170.3 mm x 43.3 mm (10.24 in. x 6.70 in. x 1.70 in.; without rubber pads)
Power supply	1 x external power adapter
Rated input voltage	12 V
Maximum input voltage	12.5 V
Rated input current	2 A
Maximum input current	3 A
Maximum power consumption	18 W
Unit weight	1.6 kg (3.53 lbs)
Operating temperature	0°C to 45°C (32°F to 113°F) at a height below 1,800 m (5,905.51 ft.) above the sea level Note: At an altitude between 1,800 m (5,905.51 ft.) and 5,000 m (16,404.20 ft.), every time the altitude increases by 220 m (721.78 ft.), the maximum temperature decreases by 1°C (1.8°F).
Operating humidity	10% RH to 90% RH (non-condensing)
Storage temperature	-40°C to 70°C (-40°F to 158°F)
Storage humidity	5% RH to 95% RH (non-condensing)
Operating altitude	0 m to 5,000 m (0 ft. to 16,404.2 ft.)

 **Caution**

Due to the wide variety of USB flash drives, the firewall may not support some of them. You are advised to use a genuine Kingston USB flash drive formatted with the FAT32 file system.

1.3.3 Cooling

The RG-CF10S-LTE adopts natural cooling. To ensure that the equipment works properly in the specified environment, maintain sufficient clearance around the equipment for air circulation and ventilation.

1.4 RG-CF30XS

1.4.1 Equipment Appearance

The RG-CF30XS provides eight 10/100/1000BASE-T ports, two 10/100/1000/2.5GBASE-T ports, two 1GE SFP ports, two 10GE SFP+ ports, one management port, one USB 3.0 port, and one console port on the front panel. The rear panel includes one SATA hard disk slot and one 4G module slot.

The nameplate is located on the bottom of the firewall. It provides information, such as the IP address of the management interface, and default login username and password.

1. Front Panel

Figure 1-5 Front Panel

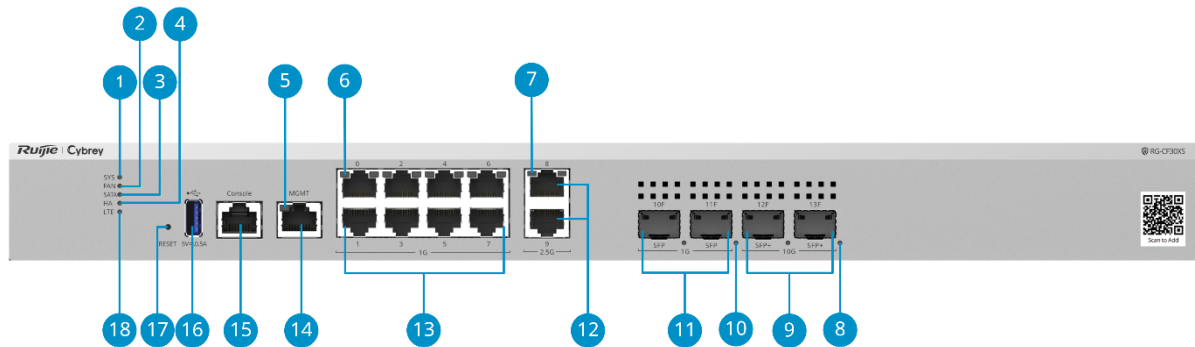

Table 1-7 Components on the Front Panel

No.	Component	Description
1	System status LED (SYS)	<ul style="list-style-type: none"> ● Solid green: The system is operating normally. ● Blinking green: The system is being initialized. If the LED is in this state for a long time, the system malfunctions. ● Solid red: A system fault occurs or the device temperature exceeds the normal operating temperature range. ● Off: The system is not powered on.
2	Fan status LED (FAN)	<ul style="list-style-type: none"> ● Solid green: The fan module operates properly. ● Solid red: The fan module malfunctions. ● Off: The fan module has no power input.
3	Hard disk status LED (SATA)	<ul style="list-style-type: none"> ● Solid green: The hard disk is installed and operates properly. ● Blinking green: The hard disk is reading or writing data. ● Solid red: A hard disk fault occurs. ● Off: No hard disk module is installed.
4	HA active/standby LED (HA)	<ul style="list-style-type: none"> ● Solid green: The HA system works normally and the device is operating in the active role. ● Blinking green: The HA system works normally and the device is operating in the standby role. ● Solid red: The HA system malfunctions. ● Off: The HA system is disabled.
5	Management port LED	<ul style="list-style-type: none"> ● Solid green: A link is set up on the port. ● Blinking green: The port is receiving or sending data. ● Off: The link on the port is Down.

No.	Component	Description
6	10/100/1000BASE-T port LED	<ul style="list-style-type: none"> ● Solid green: A link is set up on the port. ● Blinking green: The port is receiving or sending data. ● Off: The link on the port is Down.
7	10/100/1000/2.5GBASE-T port LED	<ul style="list-style-type: none"> ● Solid green: A link is set up on the port. ● Blinking green: The port is receiving or sending data. ● Off: The link on the port is Down.
8	10GE SFP+ port LED	<ul style="list-style-type: none"> ● Solid green: A link is set up on the port. ● Blinking green: The port is receiving or sending data. ● Off: The link on the port is Down.
9	10GE SFP+ ports	Two 10GE optical ports (12F and 13F), which are backward compatible with 1GE SFP ports on the peer equipment.
10	1GE SFP port status LED	<ul style="list-style-type: none"> ● Solid green: A link is set up on the port. ● Blinking green: The port is receiving or sending data. ● Off: The link on the port is Down.
11	1GE SFP ports	Two 1GE optical ports (10F and 11F).
12	10/100/1000/2.5GBASE-T ports	Two 10/100/1000/2.5GBASE-T ports (ports 8 and 9), supporting auto-negotiation at 10 Mbps, 100 Mbps, 1000 Mbps, or 2.5 Gbps and connecting Ethernet cables with RJ45 connectors.
13	10/100/1000BASE-T ports	Eight 10/100/1000BASE-T ports (ports 0–7), supporting auto-negotiation at 10 Mbps, 100 Mbps, or 1000 Mbps and connecting Ethernet cables with RJ45 connectors.
14	Management port	The management port has a default IP address (10.20.30.42/24). Upon first login, you can log in to the web management page of the device through the management port.
15	Console port	<p>Connects to the device console for device maintenance and troubleshooting.</p> <p>Note:</p> <ul style="list-style-type: none"> ● When the console port is used, set the baud rate to 115200 bps, data bit to 8, stop bit to 1, with no parity check and data flow control. ● The console port is only used in special scenarios. For detailed operations, contact technical support.
16	USB port	<p>One USB 3.0 port for connecting a USB flash drive.</p> <p>Note: External storage devices cannot be used for log storage.</p>
17	Reset button	<ul style="list-style-type: none"> ● Device restart: Press and hold the button for less than 5s. ● Factory reset: Press and hold the button for more than 5s. <p>Both operations will trigger automatic collection of equipment information. After startup, choose O&M > Fault Diagnosis > One-Click Collection, and download the equipment status information.</p>

No.	Component	Description
18	4G status LTE LED (LTE)	<ul style="list-style-type: none"> ● Solid green: The cellular service is available. ● Blinking green: The equipment is dialing. ● Solid red: The cellular service is faulty. ● Off: The cellular service is disabled.

2. Rear Panel

Figure 1-6 Rear Panel

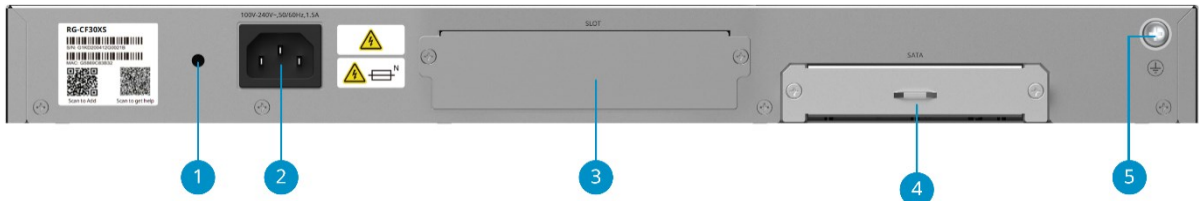

Table 1-8 Components on the Rear Panel

No.	Component	Description
1	Power cord retainer hole	Used to install the power cord retainer. It secures the power cord.
2	Power connector	Connects to the alternating current (AC) power cord.
3	4G module slot	Accommodates a 4G module. The equipment is not delivered with a 4G module by default. You need to purchase it separately.
4	SATA hard disk slot	Accommodates a hard disk to expand the storage space of the equipment. The equipment is not delivered with a hard disk by default. You need to purchase it separately.
5	Grounding screw	Connects the grounding wire to ensure electrical safety.

1.4.2 Technical Specifications

Table 1-9 Technical Specifications

Model	RG-CF30XS
Memory	4 GB DDR4 (ECC not supported)
Flash memory	64 GB eMMC
Hard disk	No hard disk for factory delivery, expansion module supported: <ul style="list-style-type: none"> ● RG-NSEC-HDD-1T-B: 1 TB ● RG-NSEC-SSD-480G-B-M: 480 GB
Fixed service port	<ul style="list-style-type: none"> ● 8 x 10/100/1000BASE-T ports ● 2 x 10/100/1000/2.5GBASE-T ports ● 2 x 1GE SFP ports: For details about the supported optical transceiver models, see Section Appendix A 1GE SFP Transceivers.

	<ul style="list-style-type: none"> ● 2 x 10GE SFP ports (1000BASE-X/10GBASE-R): For details about the supported optical transceiver models, see Section Appendix B 10GE SFP+ Transceivers.
Fixed management port	<ul style="list-style-type: none"> ● 1 x RJ45 management port ● 1 x RJ45 console port
USB port	1 x USB 3.0 port
4G port	One 4G module slot. The equipment is not equipped with a 4G module by default. You need to purchase the 4G module RG-NSEC-SIC-LTE-S separately.
Bypass port	Not supported
Expansion module	Not supported
Unit dimensions (W x D x H)	440 mm x 222 mm x 44 mm (17.32 in. x 8.74 in. x 1.73 in.; without rubber pads)
Power supply	1 x fixed power supply
Rated input voltage	100 V AC to 240 V AC, 50 Hz to 60 Hz
Maximum input voltage	90 V AC to 264 V AC, 50 Hz to 60 Hz
Rated input current	1.5 A
Maximum input current	1.5 A
Maximum power consumption	30 W
Unit weight	2.42 kg (5.34 lbs)
Operating temperature	0°C to 45°C (32°F to 113°F) at a height below 1,800 m (5,905.51 ft.) above the sea level Note: At an altitude between 1,800 m (5,905.51 ft.) and 5,000 m (16,404.20 ft.), every time the altitude increases by 220 m (721.78 ft.), the maximum temperature decreases by 1°C (1.8°F).
Operating humidity	40% RH to 65% RH (non-condensing)
Storage temperature	-40°C to 70°C (-40°F to 158°F)
Storage humidity	10% RH to 90% RH (non-condensing)
Operating altitude	0 m to 5,000 m (0 ft. to 16,404.2 ft.)

 **Caution**

Due to the wide variety of USB flash drives, the firewall may not support some of them. You are advised to use a genuine Kingston USB flash drive formatted with the FAT32 file system.

1.4.3 Cooling

The RG-CF30XS has one built-in fan and adopts the right-to-left airflow design to enable air cooling, ensuring that the equipment operates properly in the specified environment. Maintain sufficient clearance on both sides of the equipment for air circulation and ventilation.

1.5 Modules

1.5.1 Hard Disk Modules

The RG-CF30XS firewall supports hard disk modules for expanding storage, which is used to store logs and report data. Purchase hard disk models based on equipment models.

Note

The hard disks have built-in software and are formatted as EXT4. They support plug-and-play.

Caution

- Avoid vibration and impact during transportation and use.
- The original packaging must be used during transportation.
- At an altitude above 3,000 m (9,842.52 ft.), the hard disks may malfunction.
- When handling the hard disks, avoid dropping them, applying pressure to their surface, or covering their ventilation holes.

1. RG-NSEC-HDD-1T-B

The RG-NSEC-HDD-1T-B hard disk module provides a storage capacity of 1 TB. Its appearance is shown in [Figure 1-4](#).

Figure 1-7 Hard Disk Appearance

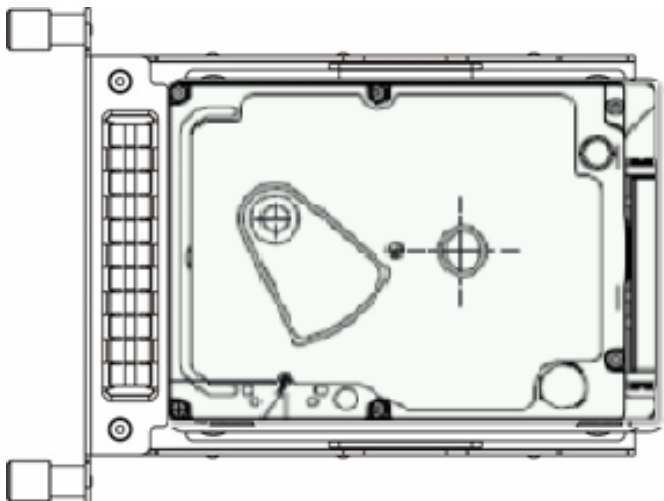

Table 1-10 Specifications

Model	RG-NSEC-HDD-1T-B
Firewall model	RG-CF30XS

Unit dimensions (W x D x H)	79.2 mm x 109.5 mm x 19.2 mm (3.12 in. x 4.31 in. x 0.76 in.)
Unit weight	0.25 kg (0.55 lbs)
Hard disk type	Mechanical hard disk
Port type	SATA
Storage capacity	1 TB
Maximum power consumption	3.5 W
Operating temperature	0°C to 60°C (32°F to +140°F)
Storage temperature	-40°C to 65°C (-40°F to +149°F)
Operating humidity	5% RH to 95% RH (non-condensing)
Storage humidity	5% RH to 90% RH (non-condensing)
Operating altitude	0 m to 3,000 m (0 ft. to 9,842.52 ft.)
Hot swapping	Not supported

3. RG-NSEC-SSD-480G-B-M

The RG-NSEC-SSD-480G-B-M can expand the storage capacity of the equipment by 480 GB.

Figure 1-8 Hard Disk Appearance

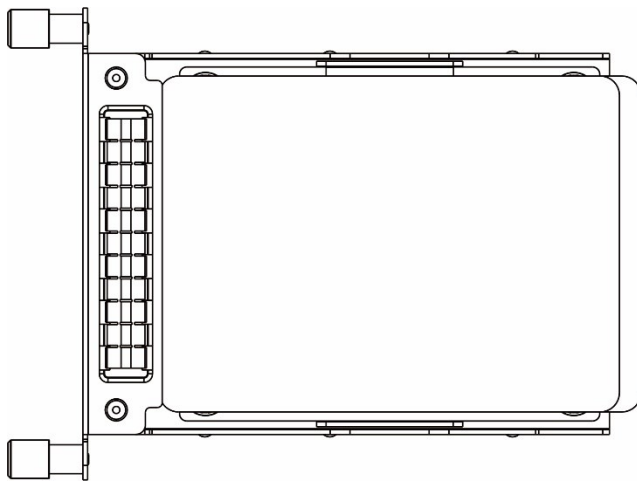

Table 1-11 Specifications

Model	RG-NSEC-SSD-480G-B-M
Firewall model	RG-CF30XS
Unit dimensions (W x D x H)	79.2 mm x 109.5 mm x 19.2 mm (3.12 in. x 4.31 in. x 0.76 in.)
Unit weight	0.2 kg (0.44 lbs)
Hard disk type	Solid state drive
Port type	SATA
Storage capacity	480 GB
Maximum power consumption	2.4 W
Operating temperature	0°C to 70°C (32°F to +158°F)
Storage temperature	-40°C to 85°C (-40°F to +185°F)
Operating humidity	5% RH to 95% RH (non-condensing)
Storage humidity	5% RH to 95% RH (non-condensing)
Operating altitude	0 m to 3,000 m (0 ft. to 9,842.52 ft.)
Hot swapping	Not supported

1.5.2 4G Module

The RG-CF30XS with 4G modules installed can provide 4G services. The equipment is not delivered with a 4G module by default. You can purchase a 4G module as required.

1. RG-NSEC-SIC-LTE-S

Figure 1-9 Appearance



Table 1-12 Components on the Panel

No.	Component	Description
1	Fastening screw	Used to secure the 4G module to the equipment.
2	4G antenna (port)	Used to receive and transmit the 3G or 4G signal and optimize the network quality.
3	SIM card slot 1 (left) and SIM card slot 2 (right)	Used to accommodate SIM cards.

Table 1-13 Specifications

Model	RG-NSEC-SIC-LTE-S
-------	-------------------

Firewall model	RG-CF30XS
4G port	1 x 4G port
Connector type	2 x SMA-J connectors (ANT 2 and ANT 1) for connecting the two antennas
Antenna	2 x 4G antennas
Supported rates	FDD-LTE: B1, B3, B5, B8; TDD-LTE: B34, B38, B39, B40, B41; WCDMA: B1, B8
SIM card	Dual SIM Single Standby Support for two micro SIM cards
Module Hot Swapping	Not supported
Unit dimensions (W x D x H)	103.37 mm x 123 mm x 28 mm (4.07 in. x 4.84 in. x 1.1 in.)
Maximum power consumption	5 W
Operating temperature	0°C to 45°C (32°F to 113°F) at a height below 1,800 m (5,905.51 ft.) above the sea level Note: At an altitude between 1,800 m (5,905.51 ft.) and 5,000 m (16,404.20 ft.), every time the altitude increases by 220 m (721.78 ft.), the maximum temperature decreases by 1°C (1.8°F).
Operating humidity	10% RH to 90% RH (non-condensing)

2 Preparing for Installation

2.1 Safety Guidelines

Note

- To avoid personal injury or equipment damage, review the safety guidelines in this chapter before you begin the installation.
 - The following safety guidelines may not include all the potentially hazardous situations.
-

Warning

- Operation of this equipment in a residential environment could cause radio interference.
 - This equipment is not suitable for use in locations where children are likely to be present.
 - Avoid vibration and impact during transportation and use.
 - The original packaging must be used during transportation.
-

Warning

The equipment contains a button cell. Swallowing a button cell can cause serious internal burns within 2 hours and may be fatal.

- Keep children away from new and used button cells.
 - If the battery compartment is not securely closed, stop using the equipment and keep it away from children.
 - If you think a button cell may have been swallowed or placed in any part of the body, seek medical assistance immediately.
-

Warning

Note: The equipment contains a lithium battery (button cell):

- If the battery is damaged, contact Ruijie technical support to replace it with the same model and dispose of the used battery properly. Do not replace the battery by yourself. Replacing the battery with an incorrect model may cause an explosion or invalidate the safety protection.
 - Exposing the battery to extremely high temperatures and/or extremely low air pressure may cause the battery to explode or leak flammable liquids or gases.
 - Throwing the battery into a fire or oven, or mechanically crushing or cutting it may cause the battery to explode.
-

2.1.1 General Precautions

- Install the equipment in a standard 19-inch rack.
- Never operate the equipment in a wet environment, and avoid any liquids inside it. Keep the chassis clean and dust-free.
- Keep the equipment away from heat sources.
- Ensure that the rack and power distribution system are properly grounded.
- Keep the equipment away from walk areas.
- During installation and maintenance, do not wear loose clothing or ornament that may get caught in the chassis.
- Keep tools and accessories away from walk areas.

2.1.2 Chassis-Lifting Guidelines

- Avoid moving the equipment frequently.
- Turn off all power supplies and disconnect all cables before lifting or moving the equipment.
- Two or more people are required to lift the chassis. Keep balance and prevent personal injuries when lifting or moving the equipment.

2.1.3 Electricity Safety

Warning

- Any deviation from standard or improper electrical operations can result in accidents such as fires or electric shocks, potentially causing severe or even fatal harm to both individuals and equipment.
 - Direct or indirect touch through a wet object on high-voltage and mains supply can bring a fatal danger.
-
- Always observe the local regulations and standards. Only qualified personnel should be allowed to operate the equipment.
 - Carefully check the work area for potential hazards, including ungrounded power system, absent safety grounds, and damp floors.
 - Locate the emergency power-off switch in the room before installation. In the case of an accident, cut off the power supply immediately.
 - Never assume that power is disconnected from a circuit. Always check.
 - Use an uninterruptible power supply (UPS), as it can prevent power outages and avoid power interference.

2.1.4 Preventing ESD Damage

- Ensure that the chassis is connected to earth ground.
- Keep the site as dust free as possible.
- Maintain appropriate humidity conditions.
- Before installing any pluggable modules, wear an anti-ESD wrist strap and make sure that it is properly grounded.
- When handling a module, do not touch its components and printed circuit board (PCB) directly with your hands.
- When storing a module, place it in a static-shielding container or lay it face up on an anti-static workbench. Do not place it randomly.
- Avoid contact between the printed circuit boards and clothing. The anti-ESD wrist strap only protects the printed circuit boards from ESD voltages on the body. ESD voltages on clothing can still cause damage.

2.1.5 Laser Safety

The equipment supports various types of optical transceivers, which are Class 1 laser products.

Pay attention to the following:

- When an optical transceiver is working, ensure that its port is connected to an optical cable or covered by a dust cap to keep out dust and prevent it from burning your eyes.
- Do not stare into an optical port.

Note

Do not approach or stare into an optical port under any circumstances. This may cause permanent damage to your eyes.

2.2 Site Requirements

The equipment must be installed indoors for normal operation and prolonged service life.

The installation site must meet the following requirements.

2.2.1 Airflow

Maintain sufficient space around air vents to ensure adequate airflow through the chassis. Manage the cables using cable ties or cable management brackets to avoid blocking air intakes.

2.2.2 Space

You are advised to have a pathway of at least 0.8 m (2.62 ft.) wide in the equipment room. This space ensures that you can move the chassis and swap the modules easily.

Do not install the equipment against a wall. Instead, maintain a minimum clearance of 0.4 m (15.75 in.) around the equipment for heat dissipation and equipment maintenance.

2.2.3 Temperature and Humidity

To ensure normal operation and prolonged service life of the equipment, maintain appropriate temperature and humidity conditions in the equipment room.

Prolonged exposure to inappropriate temperature and humidity conditions can cause damage to the equipment.

- In an environment with high relative humidity, insulating materials are prone to poor insulation or even electricity leakage.
- In an environment with low relative humidity, insulating gaskets may shrink, resulting in screw loosening.
- In a dry environment, static electricity is more likely to occur, posing a risk to the internal circuits of equipment.
- A high temperature can accelerate the aging process of insulation materials, greatly reducing the availability of the equipment and severely affecting its service life.

Table 1-14 Temperature and Humidity

Temperature		Relative Humidity	
Long-Term Operating Condition	Short-Term Operating Condition	Long-Term Operating Condition	Short-Term Operating Condition
15°C to 30°C (59°F to 86°F)	0°C to 45°C (32°F to 113°F)	40% RH to 65% RH (non-condensing)	10% RH to 90% RH (non-condensing)

Note

- The operating temperature and humidity are measured at 1.5 m (4.92 ft.) above the floor and 0.4 m (1.31 ft.) before the rack when there is no protective plate in front or on the rear of the rack.
- Short-term operation: The equipment operates continuously for no more than 48 hours at a time, or for a total of no more than 15 days per year.

2.2.4 Cleanliness

Dust poses a significant hazard to the equipment. Dust on the enclosure causes electrostatic adhesion, leading to poor contact of the metallic joints. Electrostatic adhesion is more likely to occur in an indoor environment with relatively low humidity, not only affecting the service life of the equipment, but also causing communication faults. The following table lists the requirements for dust concentration and particle size in the equipment room.

Table 1-15 Requirements for Dust

Particle Diameter	Concentration (Particles/m ³)
≥ 0.5 μm	≤ 1.4 x 10 ⁷
≥ 1 μm	≤ 7 x 10 ⁵
≥ 3 μm	≤ 2.4 x 10 ⁵
≥ 5 μm	≤ 1.3 x 10 ⁵

Apart from dust, there are also requirements on the salt, acid, and sulfide in the air of the equipment room. These harmful substances will accelerate metal corrosion and component aging. Therefore, the equipment room should be properly protected against harmful gases, such as sulfur dioxide, hydrogen sulfide, nitrogen dioxide, and chlorine gas. The following table lists the limits on harmful gases.

Table 1-16 Requirements for Gases

Gas	Average (mg/m ³)	Maximum (mg/m ³)
Sulfur dioxide (SO ₂)	0.2	1.5
Hydrogen sulfide (H ₂ S)	0.006	0.03
Nitrogen dioxide (NO ₂)	0.04	0.15
Ammonia gas (NH ₃)	0.05	0.15
Chlorine gas (Cl ₂)	0.01	0.3

 **Note**

Average refers to the average value of harmful gases measured in a week. **Maximum** refers to the upper limit of harmful gases measured in a week for up to 30 minutes every day.

2.2.5 Grounding

A proper grounding system is crucial for ensuring stable and reliable operation, as well as preventing lightning strikes and interference. Carefully check the grounding conditions at the installation site according to the grounding requirements, and complete grounding properly based on the site situation.

- **Safety Grounding**

Ensure that the rack and power distribution system are securely grounded if the equipment uses the AC power supply. Otherwise, electric shocks may occur when the insulation resistance between the power module and the chassis decreases.

 **Caution**

The building should provide a protective ground connection to ensure that the equipment is connected to a protective ground.

- Lightning Grounding

The lightning protection system is an independent system composed of a lightning rod, a downlead conductor, and a connector connected to the grounding system. The grounding system is typically used for power reference grounding and safety grounding of the rack. Lightning grounding is required only for facilities, and is not required for the equipment.

- EMC Grounding

Electromagnetic compatibility (EMC) grounding includes shielded grounding, filter grounding, noise and interference suppression, and level reference.

The grounding resistance should be smaller than 1 ohm. Connect the grounding terminal of the rack or workbench to the ground before operating the equipment.

2.2.6 Preventing Electromagnetic Interference

- Take interference prevention measures for the power supply system.
- Keep the equipment away from the grounding system or lightning protection grounding system of the power facility.
- Keep the equipment far away from high-frequency current equipment such as high-power radio transmitting stations and radar launchers.
- Take electromagnetic shielding measures when necessary.

2.2.7 Surge Protection

- Although the equipment can guard against lightning strikes, strong lightning strikes may still damage the equipment. Take the following surge protection measures: Ensure that the grounding wire of the rack is in good contact with the ground.
- Ensure that the neutral point of the AC power socket is in good contact with the ground.
- Install a power arrester in front of the power input end to enhance surge protection for the power supply.

2.2.8 Installation Site

Regardless of whether the equipment is installed in a rack or on a workbench, ensure that the following conditions are met:

- Maintain a proper clearance around the air inlets and outlets for heat dissipation.
- Some models are equipped with fans to draw in cold air from sides and dissipate heat through the rear of the chassis. Maintain a minimum clearance of 150 mm (5.91 in.) around the ventilation openings for heat dissipation. Install the equipment in a standard 19-inch rack, or place it on a clean workbench. The installation of air conditioners is recommended in hot areas.
- The installation site has a good cooling and ventilation system.
- The installation site is sturdy enough to support the weight of the chassis and its accessories.
- The installation site is properly grounded.

2.3 Tools

[Table 1-17](#) lists the tools required during equipment installation. Prepare them in advance.

Table 1-17 Tools

Tool Category	Tool
Common Tools	Phillips screwdriver, hexagon key, M6 cage nuts and matching screws, and cable ties
Dedicated Tools	ESD-preventive gloves, wire stripper, crimping pliers, and RJ45 crimping pliers

Tool Category	Tool
Relevant Equipment	Management PC, display, and keyboard

 **Note**

The equipment is delivered without a toolkit. Prepare the preceding tools by yourself.

2.4 Unboxing and Inspection

Before installing the equipment, open its accessory box and check whether all accessories are included. Accessories vary with equipment models. For details, see the *User Manual*.

3 Installing the Firewall

Caution

- Before installing the equipment, ensure that guidelines and requirements in Chapter 2 have been met.
- The equipment appearance varies according to different models. The installation flowchart provided in this chapter is for reference only. The actual installation process varies according to device models.

3.1 Installation Procedure

To avoid product damage caused by confusion or misoperations during installation, follow the installation procedure shown in the flowchart.

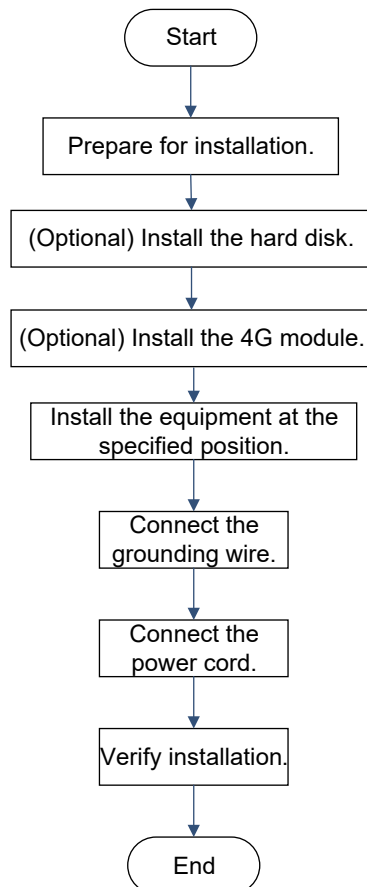

3.2 Before You Begin

Complete installation preparations according to [2 Preparing](#) for Installation and check the following items:

- The installation site provides sufficient space for heat dissipation.
- The installation site meets the temperature and humidity requirements.
- The power supply is available at the installation site, and its current meets the requirements.
- The Ethernet cables have been deployed at the installation site.

- The power supply meets the system power requirements.
- Locate the emergency power-off switch in the room before installation. In the case of an accident, cut off the power supply immediately.

3.3 (Optional) Installing the Hard Disk Module

Application Scenario

Only the RG-CF30XS supports hard disks. If you purchase a hard disk, install it according to this section to avoid damage.

Precautions

- Hard disks do not support hot swapping. Verify that the equipment is powered off before installing or removing a hard disk.
- Pay attention to the following precautions during the operation:
 - Do not block the hole on the top of the hard disk.
 - Do not press on the hard disk.
 - Do not throw, jolt, vibrate, or shake the hard disk. Hold the hard disk by its side when handling it.
 - Do not touch PCB components with bare hands or tools.

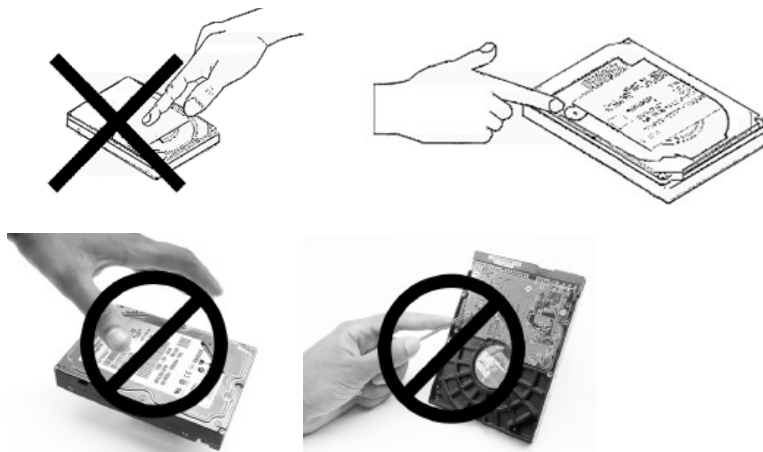

Procedure

- (1) On the rear panel of the equipment, turn the two screws on the hard disk slot cover counterclockwise to remove the cover and place it properly.
- (2) Insert the hard disk slowly and horizontally into the slot until it is fully seated.

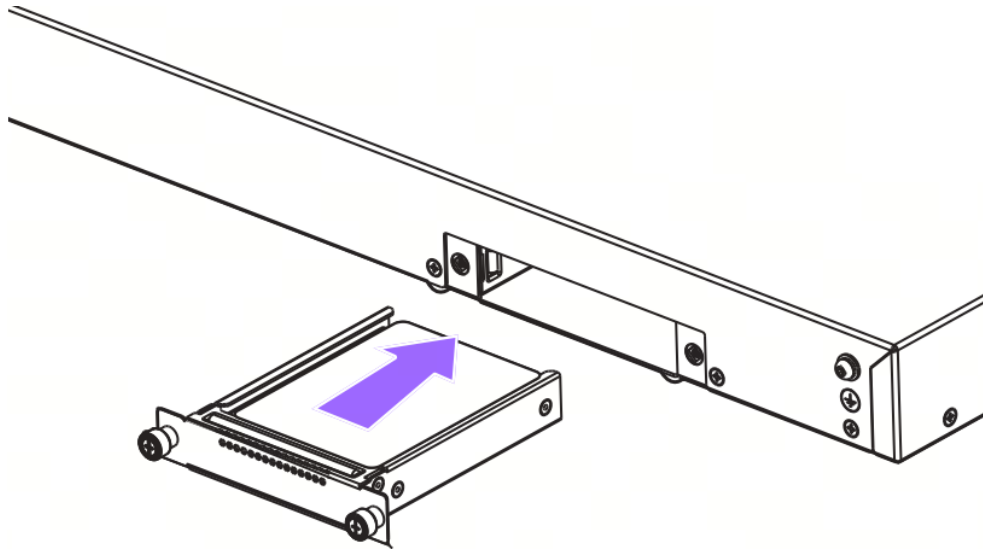

(3) Tighten the screws on the hard disk clockwise.

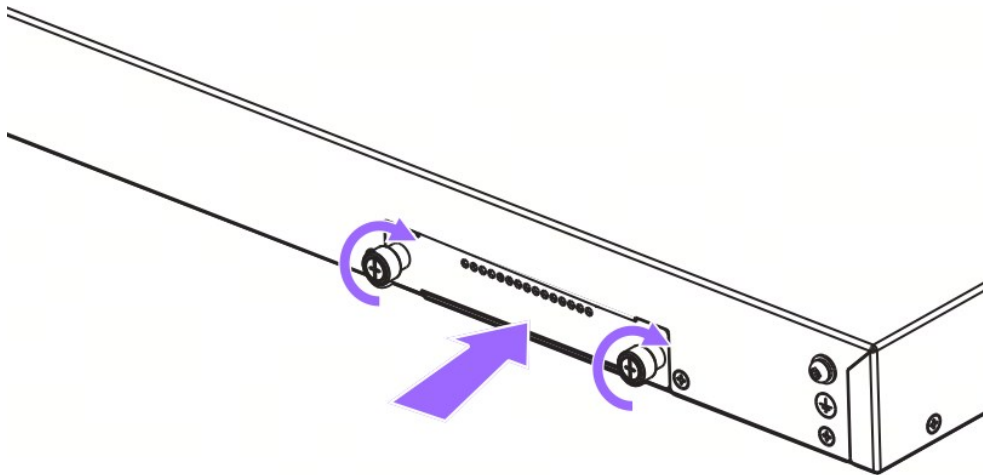

i Note

Install a hard disk slot cover on an empty slot to prevent dust ingress and ensure proper equipment ventilation.

3.4 (Optional) Installing the 4G Module

Application Scenario

Only the RG-CF30XS supports 4G modules. If you purchase a 4G module, install it according to this section to avoid damage.

Precautions

4G modules do not support hot swapping. Verify that the equipment is powered off before installing or removing a 4G module.

Procedure

- (1) On the rear panel of the equipment, turn the two screws on the 4G module slot cover counterclockwise to remove the cover and place it properly.
- (2) Align two 4G antennas with ANT ports, tighten them clockwise, and insert the 4G module slowly and horizontally into the slot until it is fully seated.

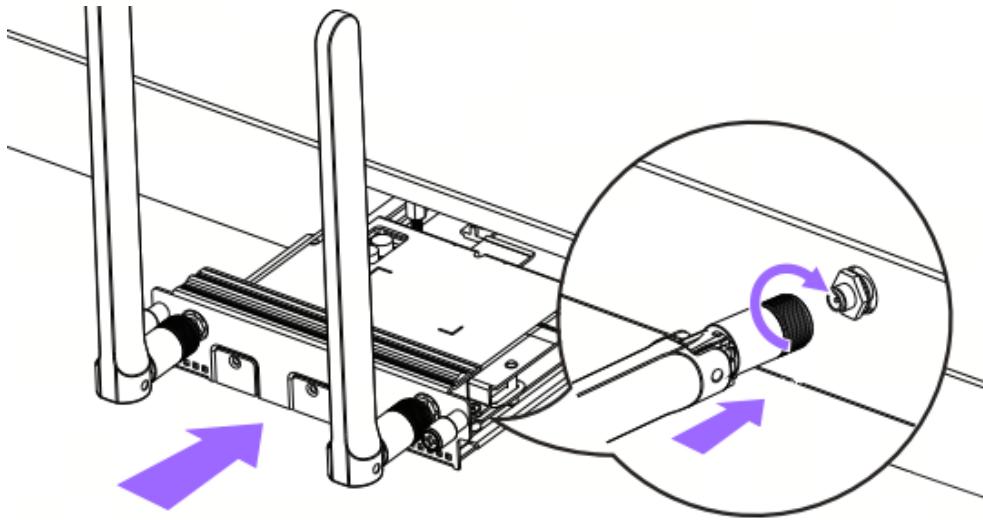

- (3) Tighten the screws on the 4G module clockwise.

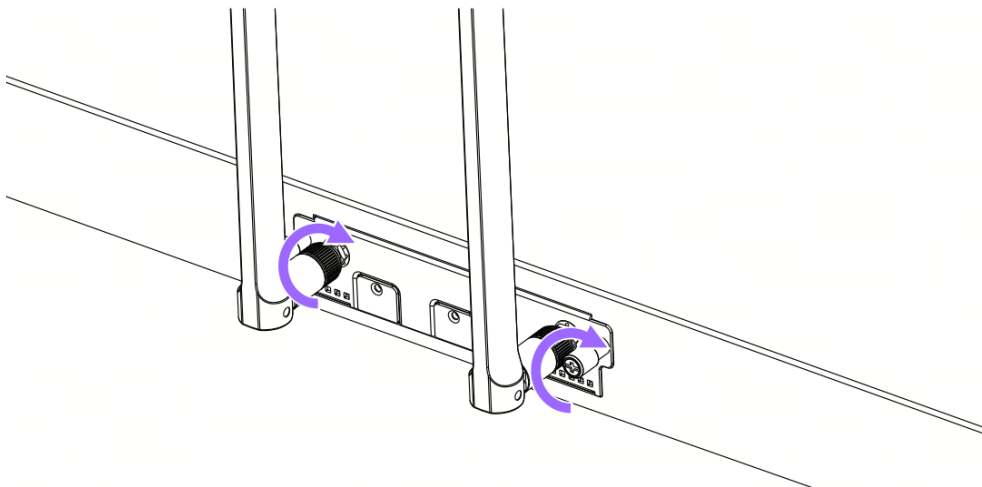

- (4) Turn the screws on the SIM card slot covers counterclockwise to remove the covers, insert the SIM cards according to the orientation indicated on the covers, and then reinstall the covers.

Note

The SIM card slots of the RG-CF10S-LTE are located on the right panel. Follow Step 4 to install SIM cards.

3.5 Installing the Equipment in a Specified Position

3.5.1 Installing the Equipment in a Rack

Application Scenario

When a standard rack is used, you can use the mounting accessories delivered with the equipment to install it.

The RG-CF30XS is designed to fit standard racks. It can be installed using the included mounting accessories.

Prerequisites

Confirm the following items before installation:

- The rack is secured.
- The equipment installation position in the rack has been determined.

Procedure

- (1) Install rack-mount brackets on both sides of the equipment.

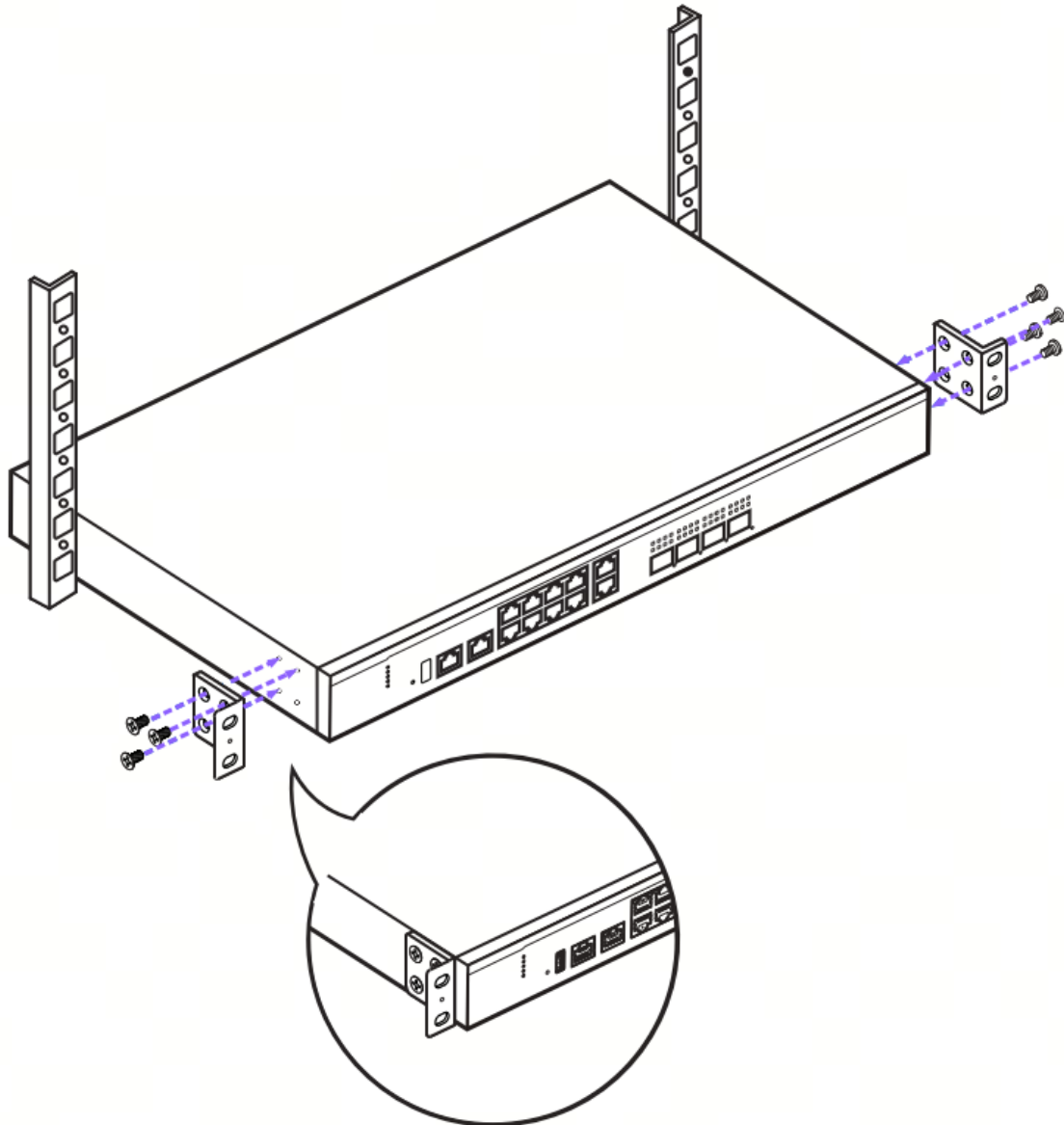

- (2) Install cage nuts on both sides of the rack.

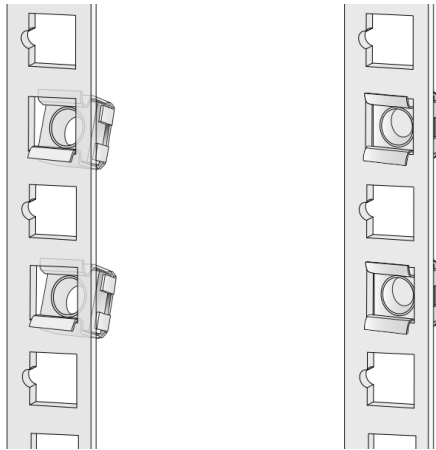

- (3) Lift the equipment from both sides and slide it horizontally into the rack, ensuring that the front rack-mount brackets are flush with the front square holes of the rack.
- (4) Align the mounting holes on rack-mount brackets with the cage nuts in the front square holes, and use M6 screws to secure the left and right rack-mount brackets to the rack.

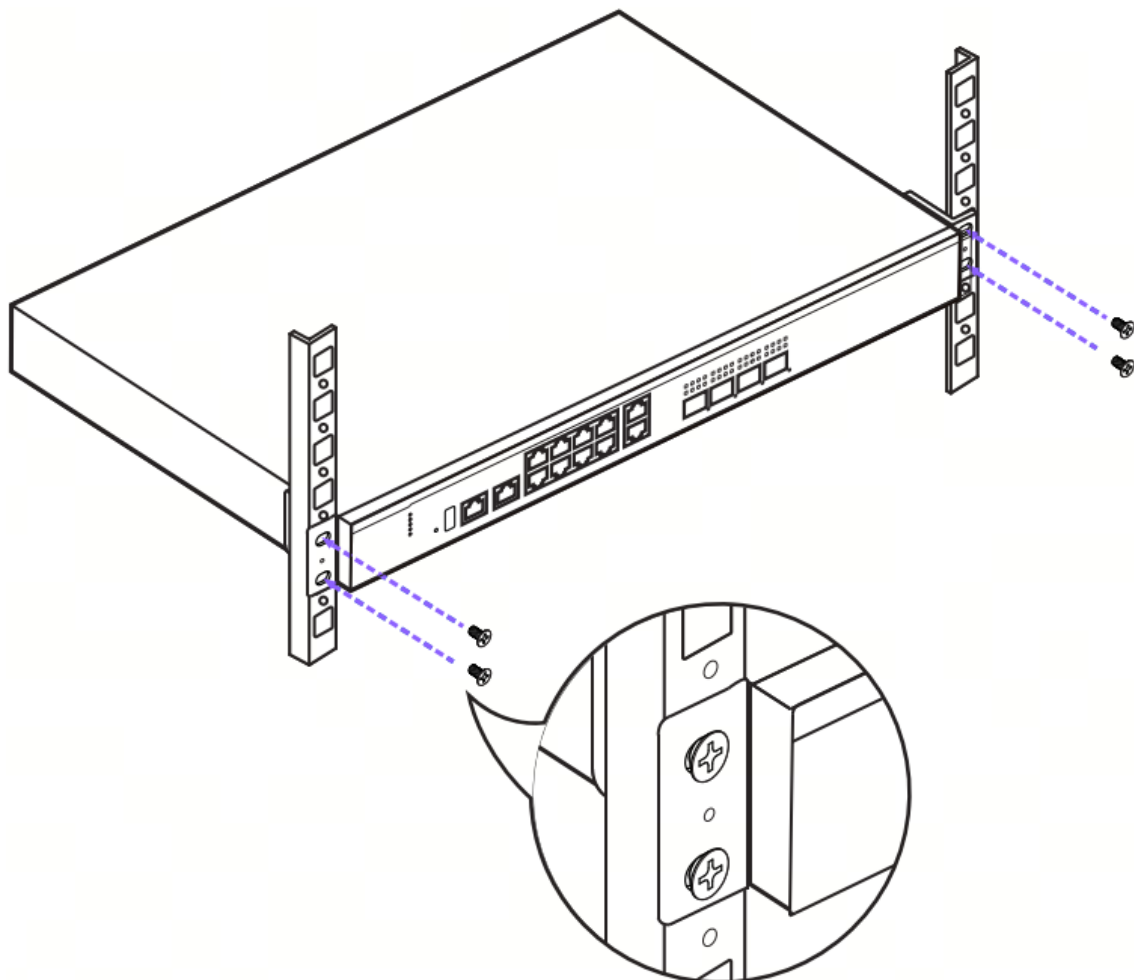

Follow-up Procedure

After the installation is complete, check the following items:

- The equipment is securely installed in the rack.
- Reserve about 1 RU of space above and below the equipment for heat dissipation.
- No objects around the equipment obstruct heat dissipation.

3.5.2 Installing the Equipment on a Workbench

Application Scenario

If a standard rack is unavailable in the installation environment, you can place the equipment horizontally on a clean workbench.

Prerequisites

Confirm the following items before installation:

- The workbench is reliably grounded.
- The workbench is clean, sturdy, and placed on a level surface.

Procedure

- (1) Attach the four rubber pads delivered with the equipment to the round, recessed areas at the four corners on the bottom.

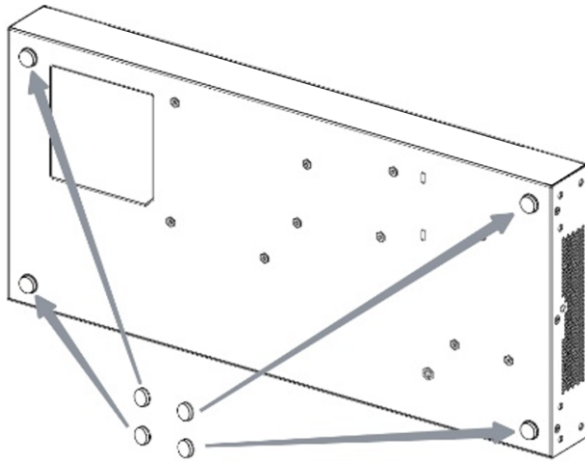

- (2) Place the equipment horizontally on the workbench (with the rubber pads facing downward).

Follow-up Procedure

After the installation is complete, check the following items:

- The equipment is securely placed on the workbench.
- A minimum clearance of 10 cm (3.94 in.) is maintained around the equipment for heat dissipation, and no object blocks heat dissipation.
- No heavy objects are placed on the equipment.

3.6 Connecting the Grounding Wire

Application Scenario

Properly connecting the grounding wire is an important measure for lightning protection and interference prevention.

Procedure

- (1) On the rear panel of the equipment, loosen the grounding screw counterclockwise.

- (2) Align the M4 end of the grounding wire with the grounding screw hole and tighten the grounding screw clockwise.

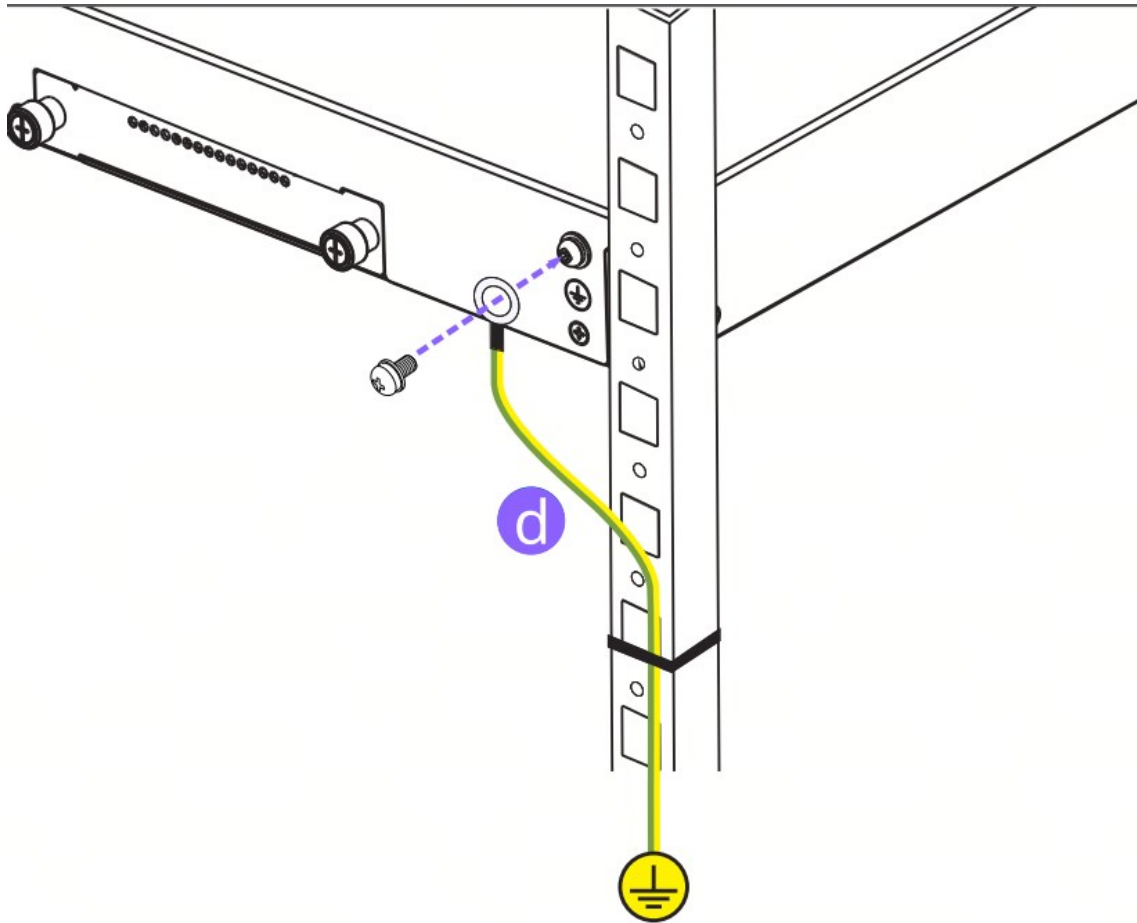

- (3) Connect the M6 end of the grounding wire to the grounding point on the rack or workbench.

Follow-up Procedure

After connecting the grounding wire, check the following items:

- The grounding wire is securely connected to the grounding lug.
- Use a multimeter to measure the grounding resistance between the grounding lug and grounding point, and ensure that the resistance is less than 1 ohm.

3.7 Connecting the Power Cord

Application Scenario

After a power module is installed in the equipment and connected to an external power supply system, the system meets the power requirement of the equipment. If two power modules are installed, connect power cords to both of them.

Prerequisites

- The power supply system meets the power requirements of the equipment.
- The equipment is properly grounded.
- The power switch of the external power supply system is in the OFF position.

Procedure

! Warning

Use the delivered power cords. Otherwise, security accidents may occur.

1. Connecting the Power Cord to the RG-CF30XS

(1) Install the power cord retainer.

- a Remove the power cord retainer from its packaging. The power cord retainer consists of a retainer strip and a retainer clamp. The retainer strip has two sides, one side smooth and the other side grooved. The adjustable retainer clamp has two sides, one side smooth and the other side grooved.

The retainer clamp has two latches. If you want to remove the retainer strip, press the retainer strip latch. If you want to adjust the retainer clamp, press the retainer clamp latch.

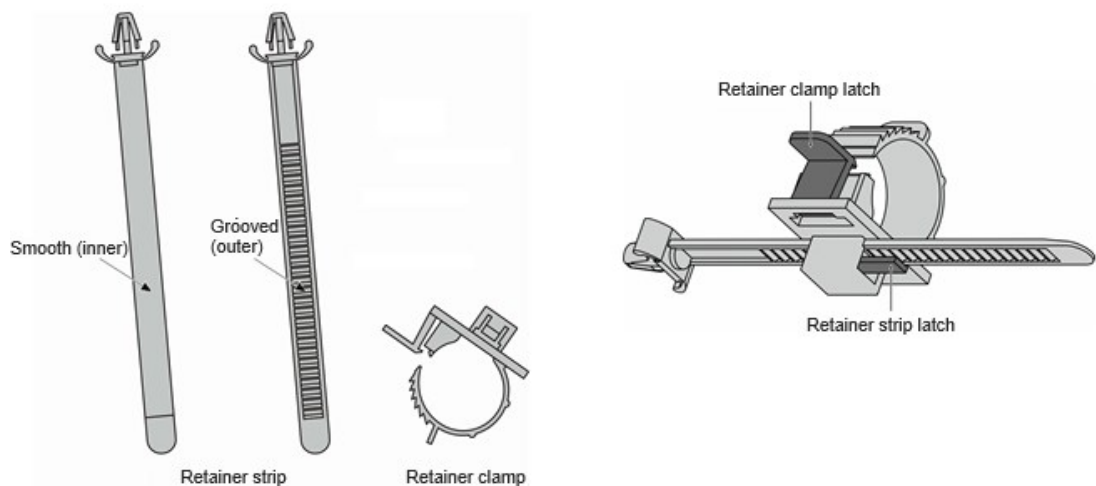

- b To assemble the power cord retainer, thread the retainer strip through the hole at the bottom of the retainer clamp. During the process, you can hear a click as the teeth engage. If you cannot pull out the retainer strip without pressing the retainer strip latch, the power cord retainer is properly assembled. To remove the retainer strip, push the retainer strip latch down in the direction shown in the following figure.

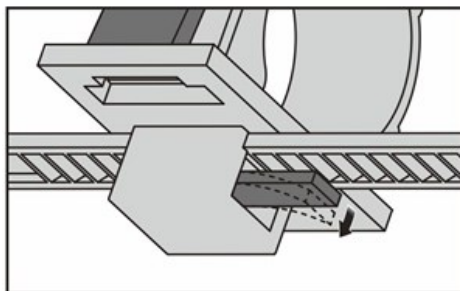

- (2) Insert the assembled power cord retainer into the installation hole on the rear panel of the equipment and ensure that the power cord retainer is securely installed.
- (3) Route the power cord through the retainer clamp, and insert the power plug into the power connector on the rear panel of the equipment.

- (4) Slide the retainer clamp to an appropriate position along the retainer strip, and adjust the retainer clamp latch to lock the power cord in place.

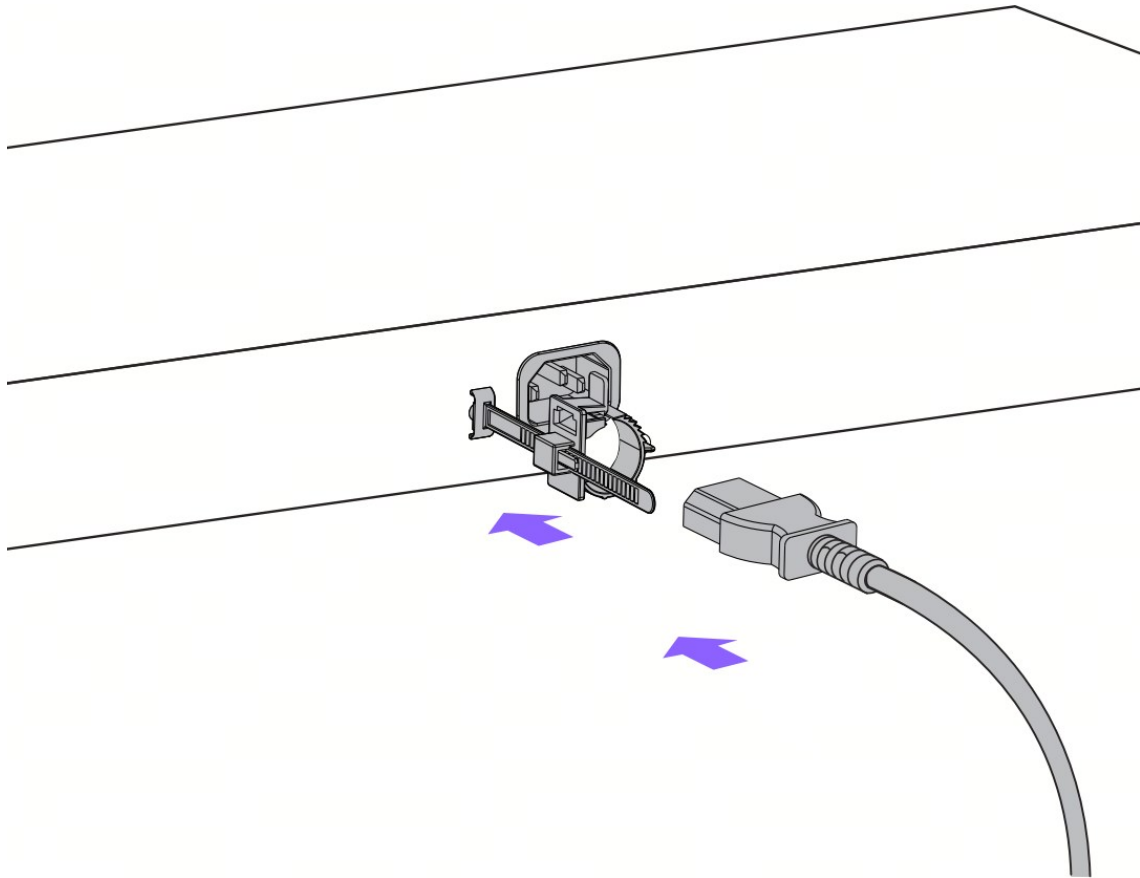

- (5) Insert the other end of the power cord into an external AC power socket.

2. Connecting the Power Cord to the RG-CF10S or RG-CF10S-LTE

- (1) Verify that the power cord retention clip around the power connector is properly installed.
- (2) Connect one end of the power cord to the power adapter delivered with the equipment.
- (3) Connect the other end of the power adapter to the 12 V power connector on the front panel of the equipment.
- (4) Snap the power cord retainer clip into place to secure the power cord.

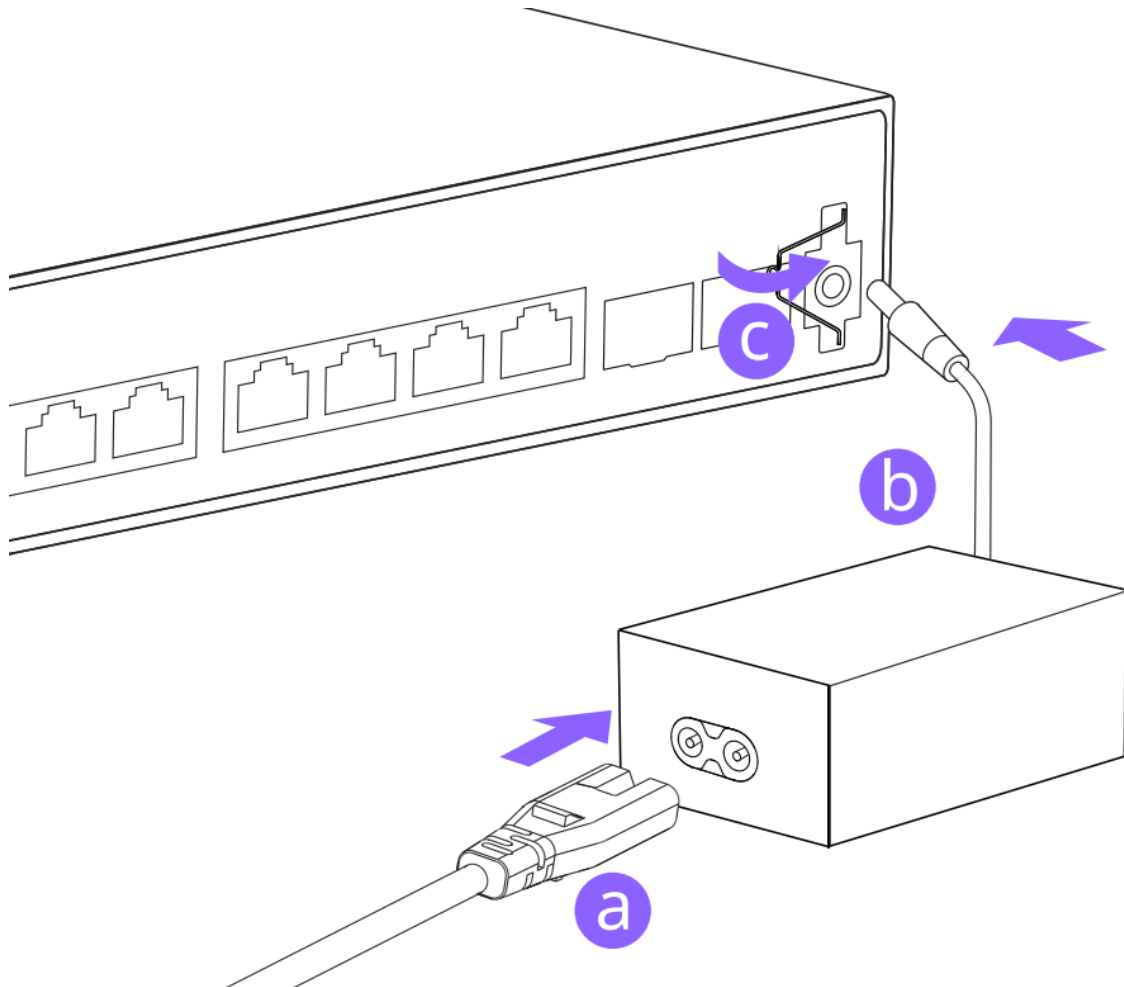

(5) Connect the other end of the power cord to the external power socket.

Follow-up Procedure

After the power cord is connected, check whether it is securely connected to the power socket.

3.8 Verifying Installation

After installation, check the following items before powering on the equipment to ensure normal operation.

- If the equipment is installed in a rack, verify that it is securely mounted and that sufficient clearance is provided around it for heat dissipation. If the equipment is installed on a workbench, verify that sufficient clearance is provided around it for heat dissipation and that the workbench is stable.
- The specifications of the external power supply system meet requirements of the equipment.
- The grounding wire of the equipment is properly connected.
- The power cord is correctly and reliably connected. The power cord is long enough to avoid being tightened, which reduces its service life.
- The equipment is correctly connected to other equipment, such as a configuration endpoint.

4 Commissioning

4.1 Setting Up the Configuration Environment

Prerequisites

[Table 1-1](#) lists the default settings for the RG-CF series.

Table 1-1 Factory Settings

Login address	10.20.30.42/24
Login port	Management port
Username and Password	Default username: admin Default password: admin

Procedure

- (1) Connect the Ethernet port of a management PC to the management port of the equipment using an Ethernet cable.

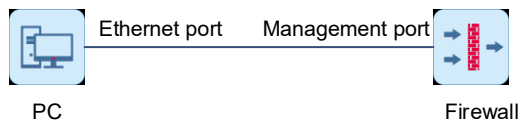

- (2) Set the IP address of the PC to be in the same subnet as the management port of the equipment and to be an unused IP address, for example, 10.20.30.1/24.

4.2 Power-on

4.2.1 Checklist Before Power-on

- The equipment is properly grounded.
- The power cord is reliably connected.
- The input voltage meets the requirement.
- The Ethernet cables are correctly connected.

4.2.2 Power-on

Turn on the power switch of the power supply system.

4.2.3 Checklist After Power-on

Check whether the equipment is working properly based on its LEDs.

Table 1-2 LED Status After Power-on

LED Name	Normal Status
System status LED (SYS)	Solid green
Fan status LED (FAN)	Solid green
Hard disk status LED (SATA)	Solid green
HA active/standby LED (HA)	Solid green (active equipment) or blinking green (standby equipment)
4G status LTE LED (LTE)	Solid green

4.3 Configuring the Equipment

Open a browser on the management PC, enter <https://10.20.30.42> in the address bar, and press Enter to log in to the web management page of the equipment to configure services. For details about the device configuration, see the *User Manual* of the corresponding version.

5 Troubleshooting

5.1 Optical Port Is Down

5.1.1 Issue Description

The system operates properly. After an optical transceiver is inserted into the optical port and an optical cable is properly connected, the optical port is still Down.

5.1.2 Solution

Troubleshoot the fault according to the following steps:

- (1) Check whether the receive and transmit ends of the optical fibers are reversed. The transmit end of the local optical port must be connected to the receive end of the peer optical port. Swap the connections of the two fibers in the optical transceiver and try again.
- (2) Check whether the optical transceivers on both ends work at the same wavelength. For example, an optical transceiver working at 1,310 nm cannot be connected to an optical transceiver working at 1,550 nm.
- (3) Check whether the distance between the two ends exceeds the length marked on the optical transceivers.
- (4) Check whether the rates of the interconnected optical transceivers are consistent and whether the fiber type meets the requirements.
- (5) For equipment whose optical ports support multiple rates, check whether the port rate mode is configured correctly, that is, the rates on both ends are consistent.
- (6) If the fault still persists, contact Ruijie technical support.

Appendix A. 1GE SFP Transceivers

We provide matching SFP transceivers (Mini-GBIC) according to the port types. You can purchase the transceivers to meet your specific needs. In addition to the following optical transceivers, a 1GE SFP port also supports the 1GE SFP copper transceivers (Mini-GBIC-GT). This appendix provides models and technical specifications of some 1GE SFP transceivers for reference. For details about the technical specifications, see *Ruijie Optical Transceiver Hardware Installation and Reference Guide*.

Table 5-1 1GE Mini-GBIC (SFP) Models and Technical Specifications

Model	Wavelength (nm)	Fiber Type	DDM Supported (Yes/No)	Transmit Power (dBm)		Receive Power (dBm)	
				Min	Max	Min	Max
MINI-GBIC-SX-MM850	850	MMF	Yes	-9.5	0	-17	0
MINI-GBIC-LX-SM1310	1310	SMF	Yes	-9	-3	-19	-3
MINI-GBIC-LH40-SM1310	1310	SMF	Yes	-5	0	-23	-3

Table 5-2 1GE SFP Copper Transceivers

Standard	1000BASE-T SFP Model	DDM Supported (Yes/No)
1000BASE-T	Mini-GBIC-GT	No

Table 5-3 Cabling Specifications of SFP Transceivers

SFP Transceiver Model	Port Type	Fiber Type	Core Size (μm)	Max Cabling Distance
MINI-GBIC-SX-MM850	LC	MMF	50/125	500 m (1,640.42 ft.)
MINI-GBIC-LX-SM1310	LC	SMF	9/125	10 km (6.21 miles)
MINI-GBIC-LH40-SM1310	LC	SMF	9/125	40 km (24.85 miles)

Caution

- For optical transceivers with a cabling distance of no less than 40 km (24.85 miles), install an optical attenuator to avoid overload on an optical receiver when using short-distance SMFs.
- An optical transceiver is a laser transmitter. Do not look into the light source to prevent it from burning your eyes.
- To keep the optical transceiver clean, make sure that the unused ports remain capped.

Appendix B. 10GE SFP+ Transceivers

We provide matching 10GE SFP+ transceivers according to the port types. You can purchase the transceivers to meet your specific needs. This appendix provides models and technical specifications of some 10GE SFP+ transceivers for reference. For details about the technical specifications, see *Ruijie Optical Transceiver Hardware Installation and Reference Guide*.

Table 5-4 Models and Technical Specifications of 10GE SFP+ Transceivers

Model	Wavelength (nm)	DDM Supported (Yes/No)	Fiber Type	Transmit Power (dBm)		Receive Power (dBm)	
				Min	Max	Min	Max
XG-SFP-LR-SM1310	1310	Yes	SMF	-8.2	0.5	-14.4	0.5
XG-SFP-ER-SM1550	1550	Yes	SMF	-4.7	4	-11.3	-1
XG-SFP-SR-MM850	850	Yes	MMF	-7.3	-1	N/A	N/A
XG-SFP-ZR-SM1550	1550	Yes	SMF	0	4	N/A	N/A
XG-SFP-LR10-SM1270-BIDI-I	1270 nm TX 1330 nm RX	Yes	SMF	-8.2	0.5	N/A	N/A
XG-SFP-LR10-SM1330-BIDI-I	1330 nm TX 1270 nm RX	Yes	SMF	-8.2	0.5	N/A	N/A
XG-SFP-T	N/A	No	SMF	N/A	N/A	N/A	N/A

Table 5-5 Cabling Specifications of SFP+ Transceivers

Model	Port Type	Fiber Type	Core Size (μm)	Modal Bandwidth (MHz·km)	Max. transmission distance
XG-SFP-LR-SM1310	Duplex LC	SMF	9/125	N/A	10 km (32,808.40 ft.)
XG-SFP-ER-SM1550	Duplex LC	SMF	9/125	N/A	40 km (131,233.60 ft.)
XG-SFP-SR-MM850	Duplex LC	MMF	N/A	N/A	300 m (984.25 ft., with OM3 optical cables) 400 m (1312.34 ft., with OM4 optical cables)
XG-SFP-ZR-SM1550	Duplex LC	SMF	N/A	N/A	80 km (262,467.19 ft.)
XG-SFP-LR10-SM1270-BIDI-I	BIDI LC	SMF	N/A	N/A	10 km (32,808.40.13 ft.)

Model	Port Type	Fiber Type	Core Size (μm)	Modal Bandwidth (MHz·km)	Max. transmission distance
XG-SFP-LR10-SM1330-BIDI-I	BIDI LC	SMF	N/A	N/A	10 km (32,808.40.13 ft.)
XG-SFP-T	RJ45	Cat 6a/7	N/A	N/A	100 m (328.08 ft.)

⚠ Caution

- For the XG-SFP-ER-SM1550, do not use short-distance optical cables for connection to avoid overloading the optical receiver of the optical transceiver. If the optical power at the receive end of the optical transceiver is greater than or equal to -1 dBm, an appropriate optical attenuator should be installed at the receive end to reduce the optical power below -1 dBm.
- An optical transceiver is a laser transmitter. Do not look into the light source to prevent it from burning your eyes.
- To keep the optical transceiver clean, make sure that the unused ports remain capped.

Table 5-6 Models and Specifications of 10GE SFP+ Cable Modules

Model	Module Type	Connector Type	Cable Length (M)	Conductor Diameter (AWG)	Data Speed (Gbps)	DDM Supported (Yes/No)
XG-SFP-AOC1M	Active optical cable	SFP+	1	\	10.3125	Yes
XG-SFP-AOC3M	Active optical cable	SFP+	3	\	10.3125	Yes
XG-SFP-AOC5M	Active optical cable	SFP+	5	\	10.3125	Yes

i Note

No additional cable needs to be connected when an SFP+ cable is used. You only need to plug both ends of the SFP+ cable into the corresponding ports of the equipment.